

Instruction

# Plastic Joining Artical

by CNZHENBO | MP Sonic



**Zhejiang Zhenbo Precision Machinery Co.,Ltd**

by Alex Lee  
28-02-2-22

**Ultrasonic welding**, including ultrasonic plastic welding & metal, means applied a ultrasonic generator which is as a power supply of ultrasonic system to convert supplied electric in low frequency, such as 220V or 380V, to the ultrasonic frequency, normally 15KHz to 70KHz, and supplies to ultrasonic transducer which also called as converter, by which the electrical energy is transfer into mechanism oscillation energy to work on work-pieces and case the internal oscillation and friction between molecules of material to generate heat and melt material, by which the molten material at the contacting area infiltrate into each other and stick together to form welding. Here, please be note that normally we do not finish through working transducer directly to work-pieces, because the wave from transducer is very short whose oscillation power is not enough to melt material, but it requests booster and horn (also called as sonotrode) to enhance the wave amplitude and work on work-pieces by a ultrasonic horn.

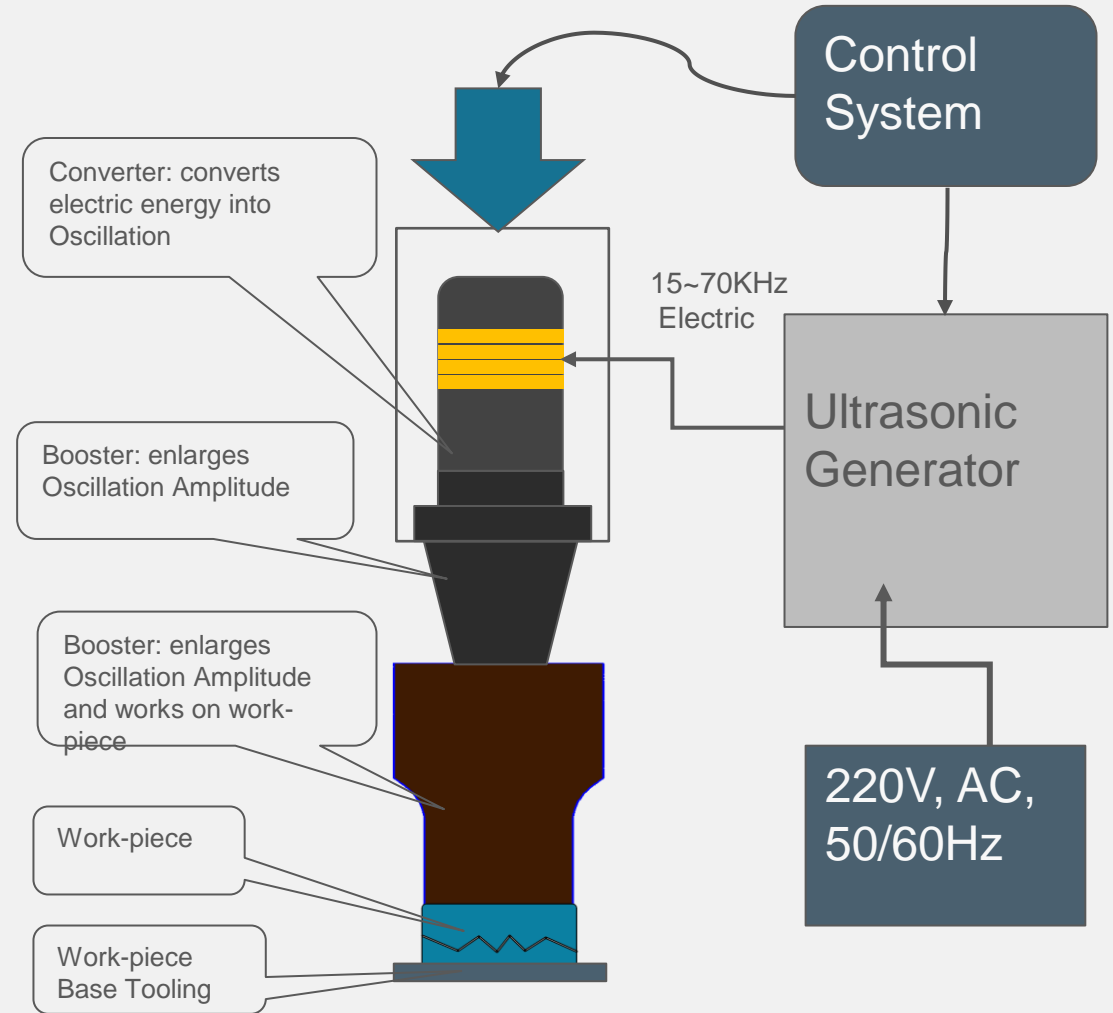

Main Parameters of ultrasonic Welding : welding time, holding time, pressure, energy, amplitude, welding depths, etc.



# Ultrasonic Plastic Welding--The Critical Parameters for Welding

The critical parameters of ultrasonic welding including time, amplitude and pressure affects welding performance the mostly, which can be referred as below illustration.

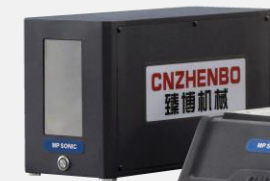
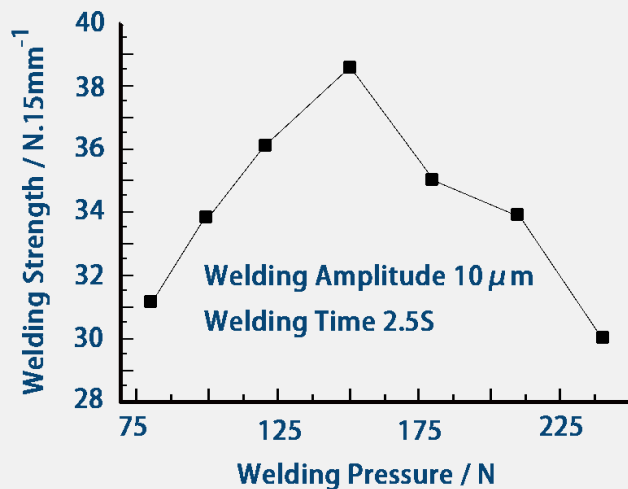
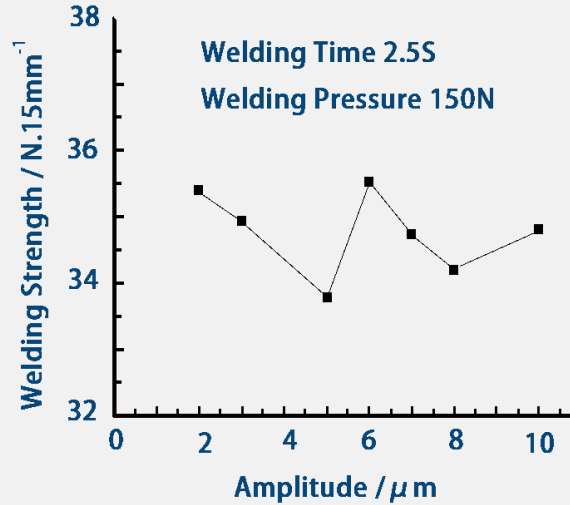
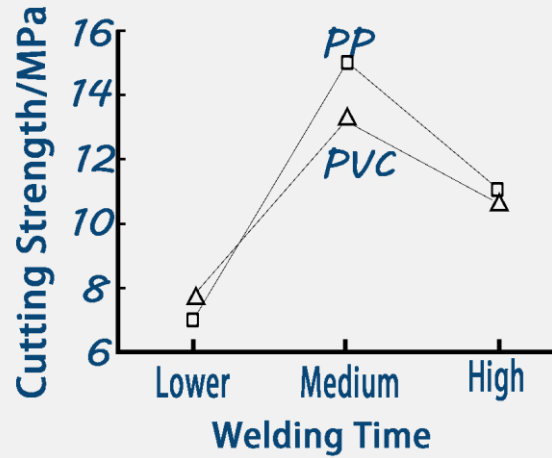



Energy director means the ultrasonic welding rib, which can make it easy focus ultrasonic energy to case material melting in short time. It case material displacement by molten thermoplastic material to form bonding.

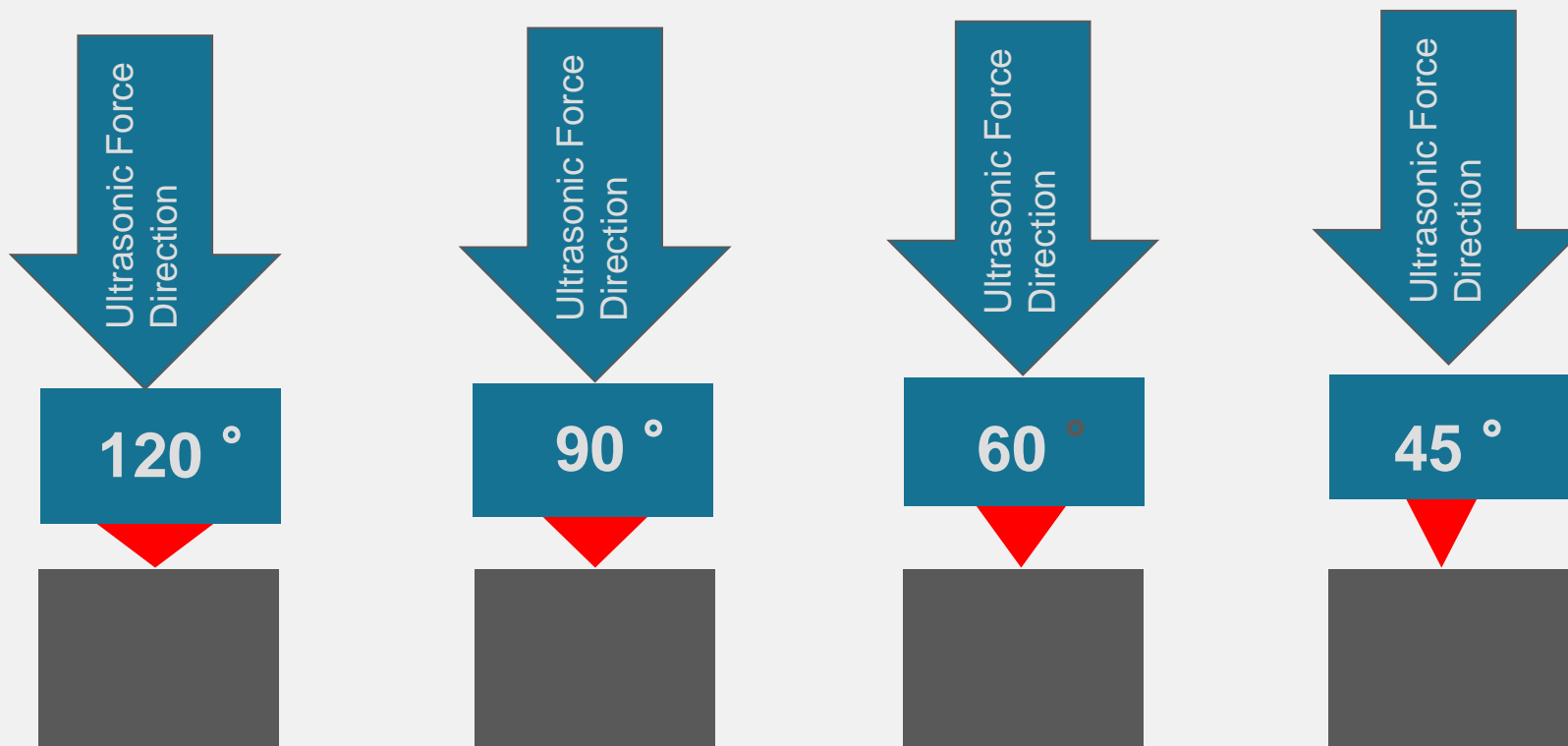



Butt Joint Design is mostly applied for ultrasonic welding with no high requirement. It is with advantages of simple design complex and small space requested.

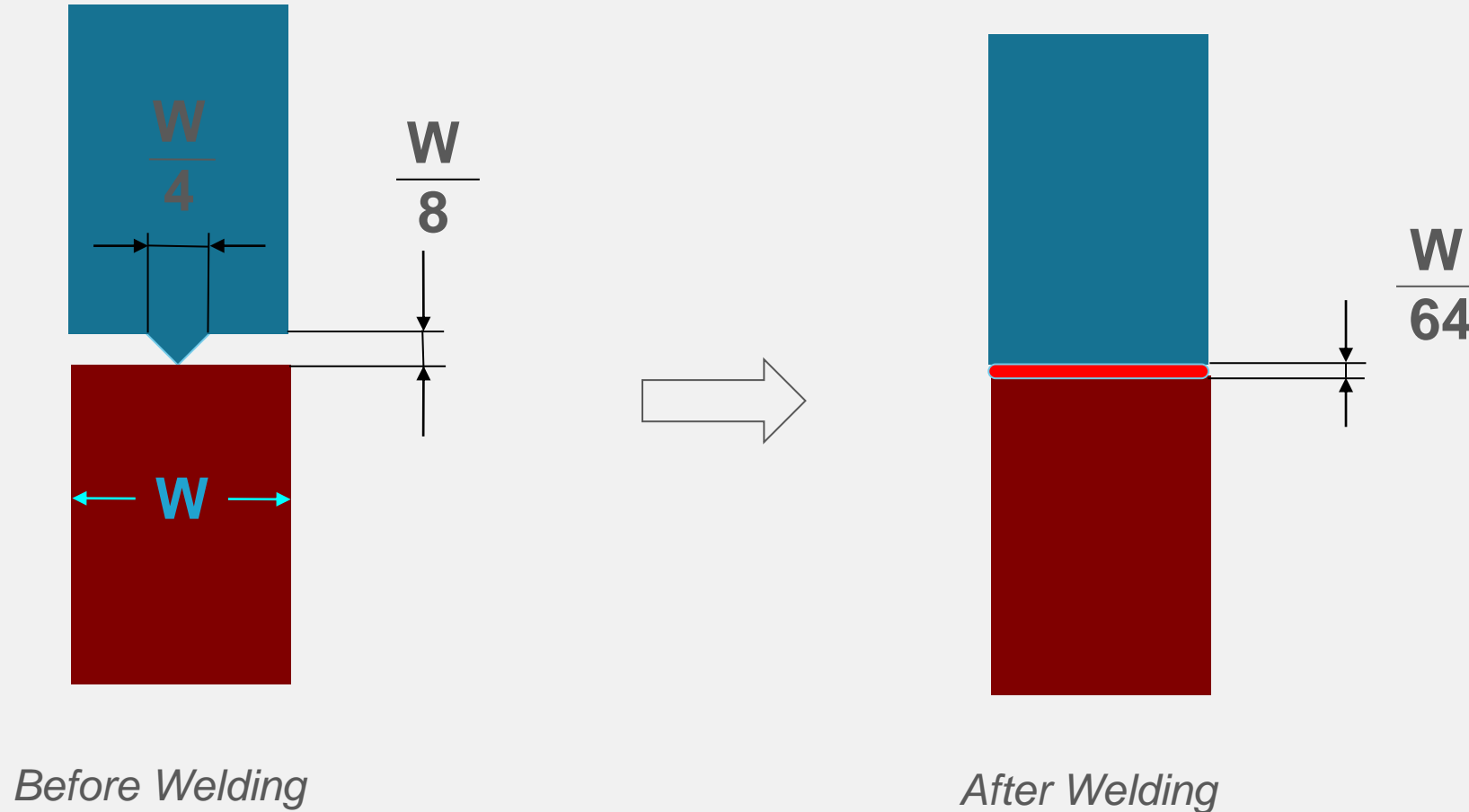

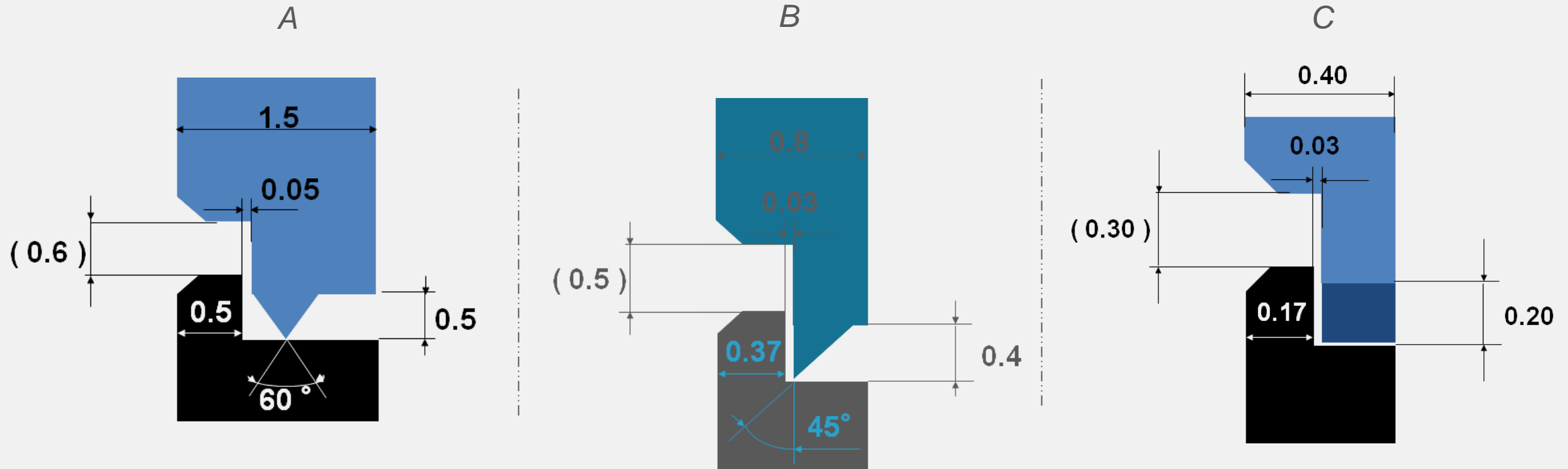

This kind of joint design provides better welding strength, air-tightness, and material flash prevention than butt welding design, because the material displacement is kept inside of the jointing area, achieving more bonding at the welding area.

For some part ultrasonic welding, especially for some challenging material, it request energy direction design on the welding surface of the other plastic part half against the welding rib, for better friction by ultrasonic oscillation to generator heating energy and material melting.

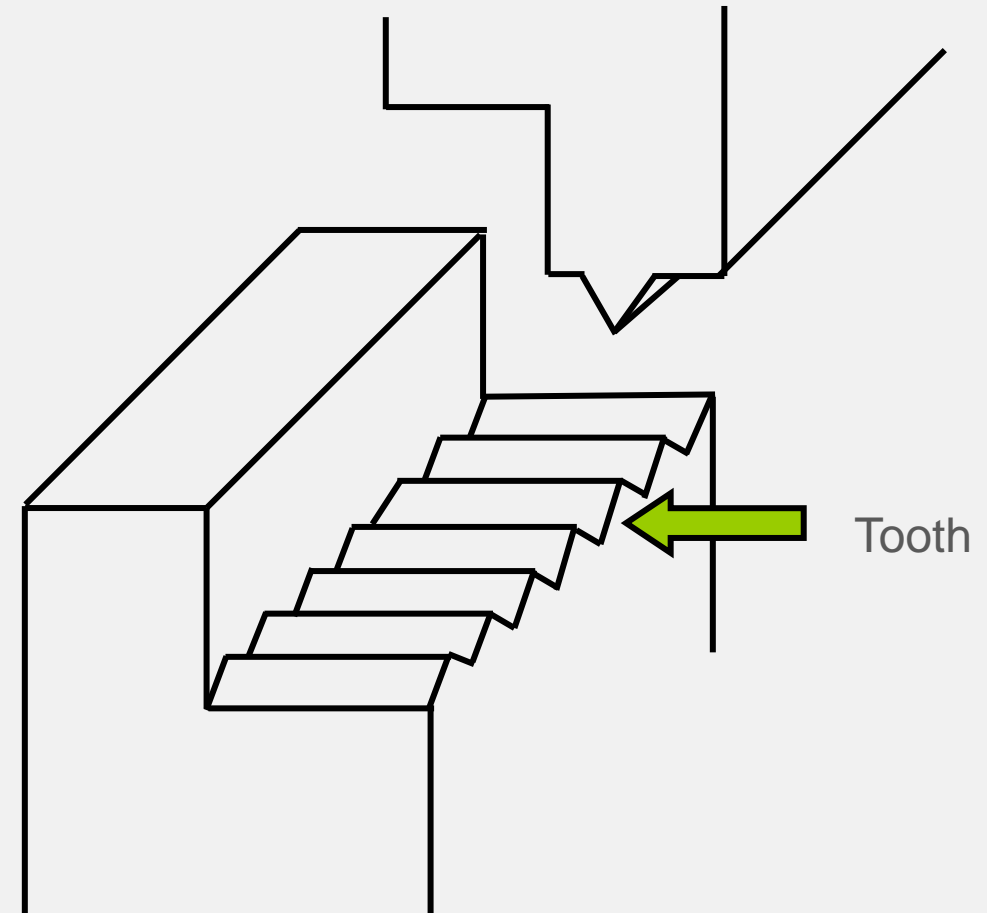
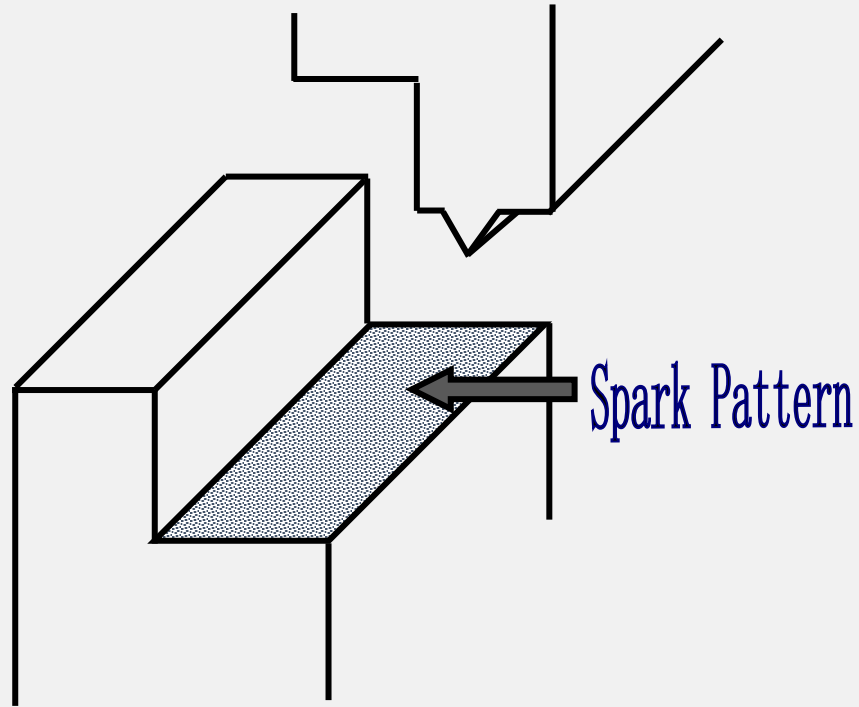

Welding Robs Height	Pattern Depth
0.13~0.29	75 μm
0.30~0.44	115 μm
0.45 or more	150 μm

$$\text{Tooth Depth} \approx \text{Welding Rib Height} * 60^\circ$$

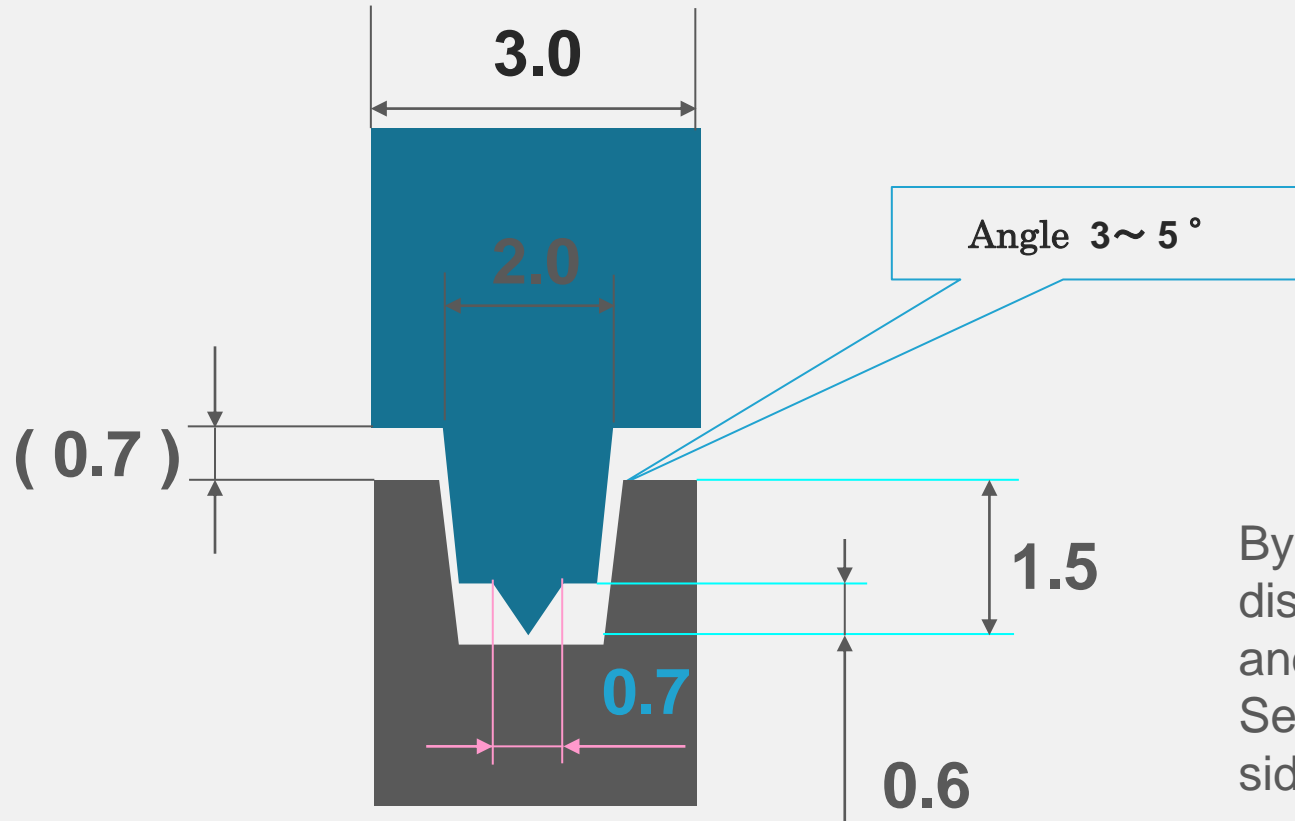

By tongue & groove joint design, the material displacement achieves the best welding strength and airtightness. And it is mostly applied for: A. Self-assembly; B. Flash prevention at both inner side and outer side.



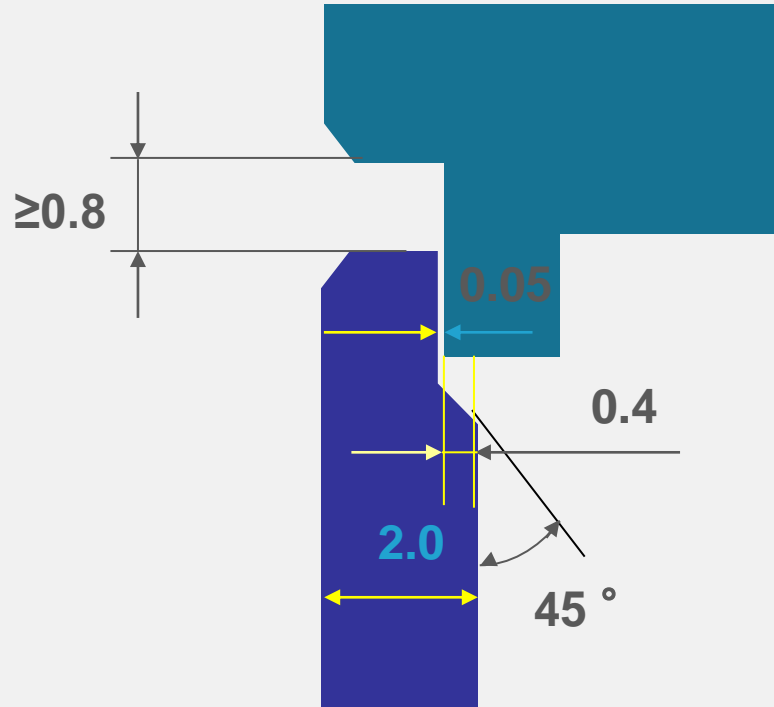

Shear joint design normally is recommended for parts welding square corners or rectangular design, whose space is limited to tongue & groove design. It requests support at welding area in strength.

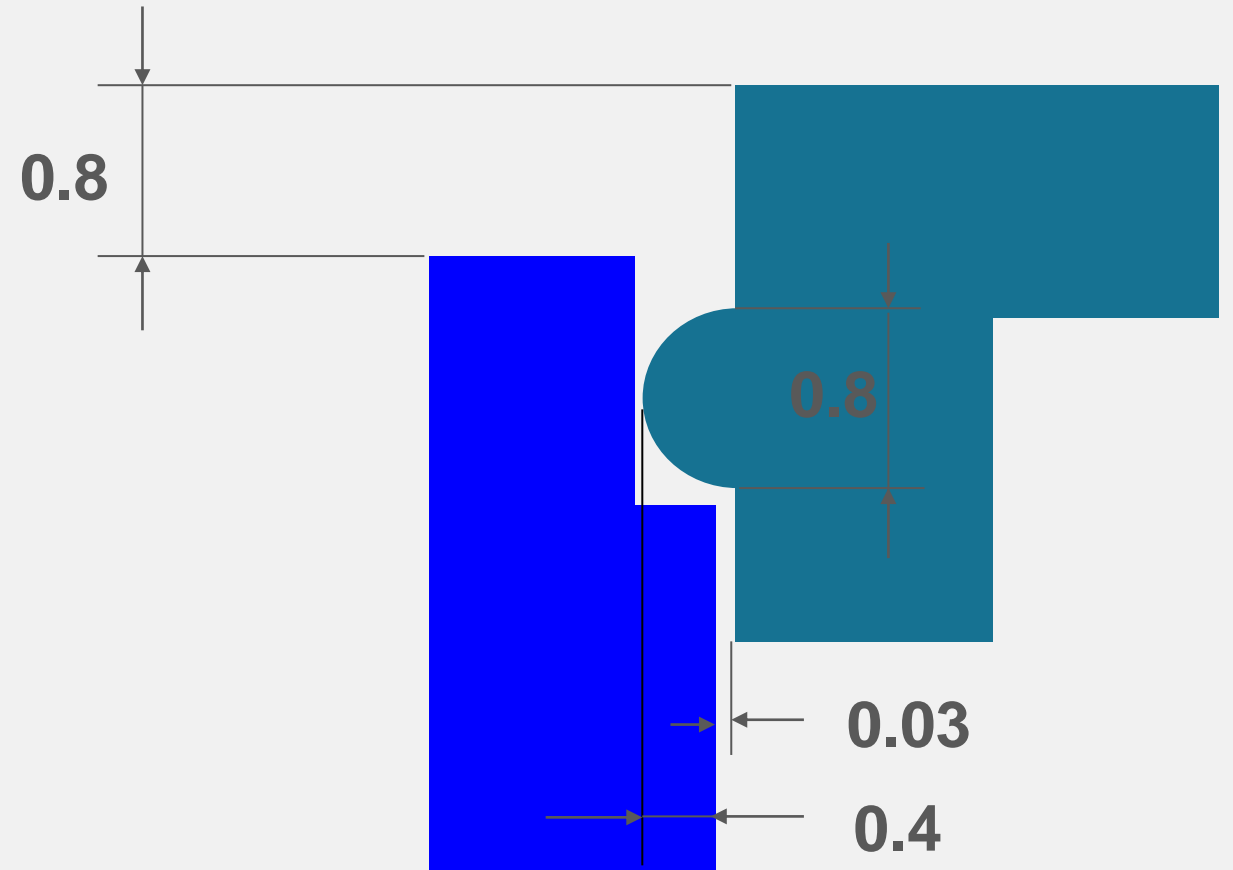

Maximum Part Dimension	Interference per Side (Range)	Part Dimension Tolerance
Less than 0.75" (18mm)	0.008" to 0.012" (0.2 to 0.3mm)	$\pm 0.001$ " ( $\pm 0.025$ mm)
0.75" to 1.50" (18-35mm)	0.012" to 0.016" (0.3 to 0.4mm)	$\pm 0.002$ " ( $\pm 0.050$ mm)
Greater than 1.50" (35mm)	0.016" to 0.020" (0.4 to 0.5mm)	$\pm 0.003$ " ( $\pm 0.075$ mm)

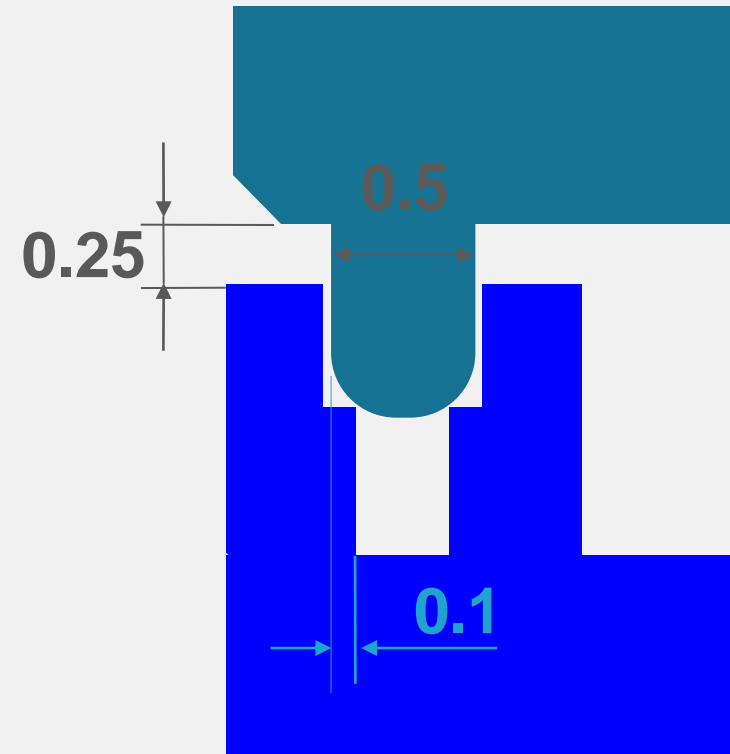
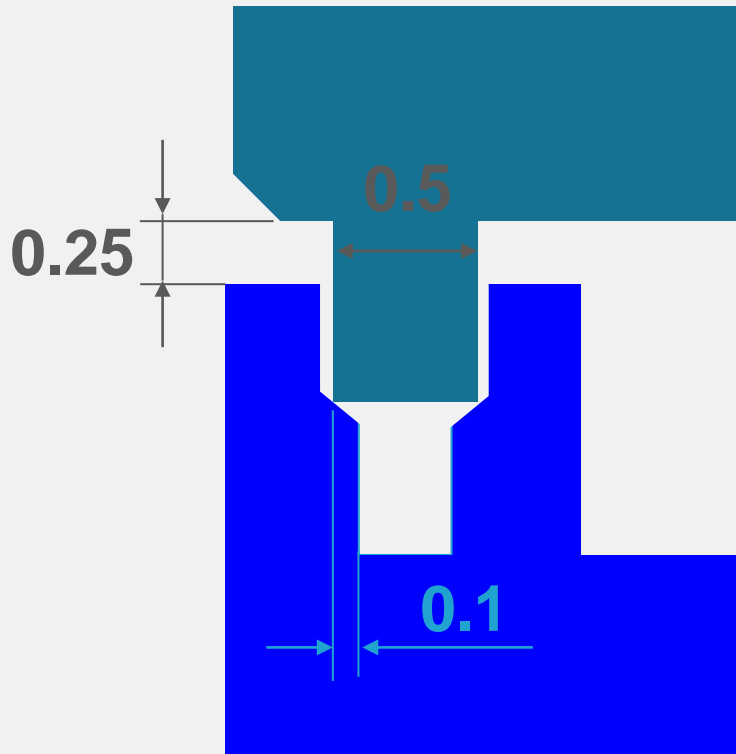

This kind of design is mostly for large welding with high requirements in hermetic seal and welding strength when limited space for welding design.

This kind of design requests high injection precision.



# Ultrasonic Stacking Design

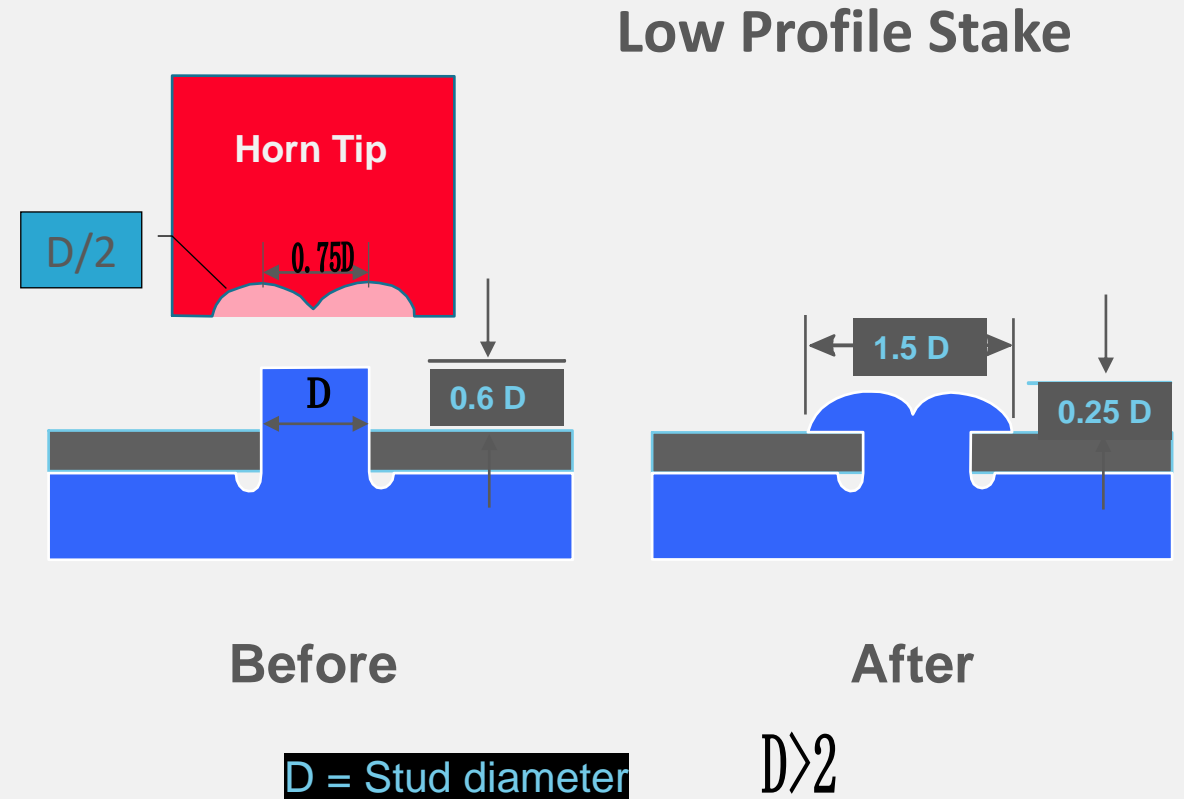
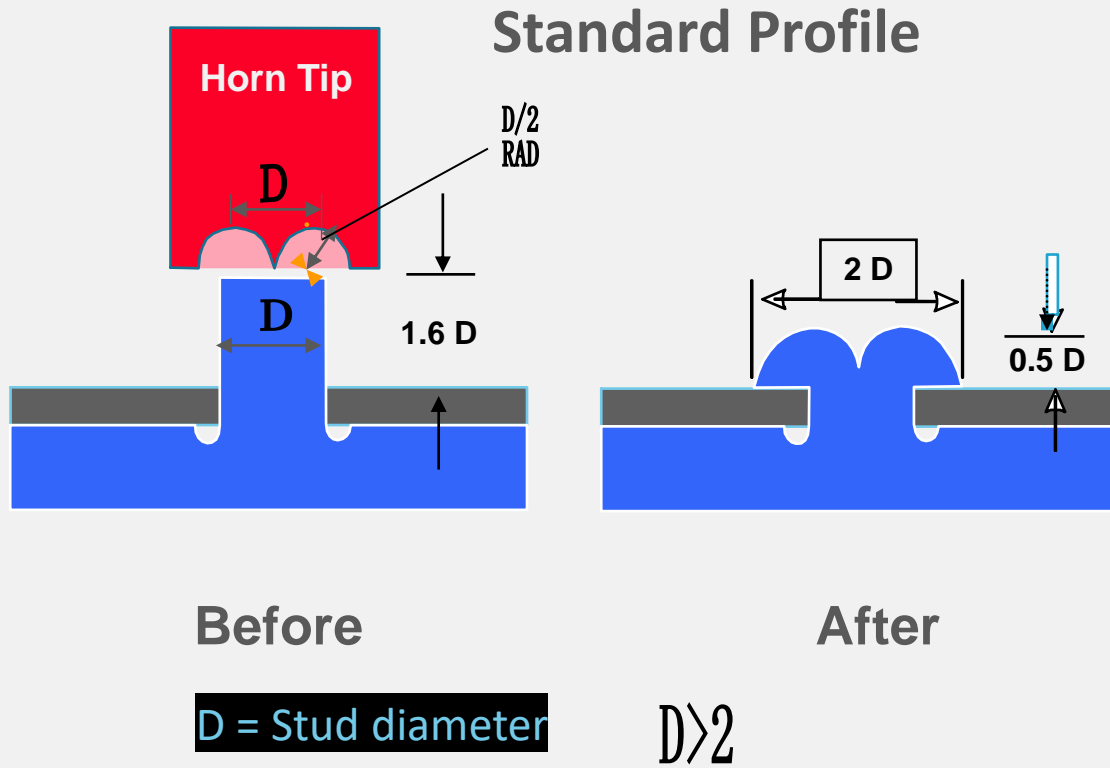



# Ultrasonic Plastic Welding

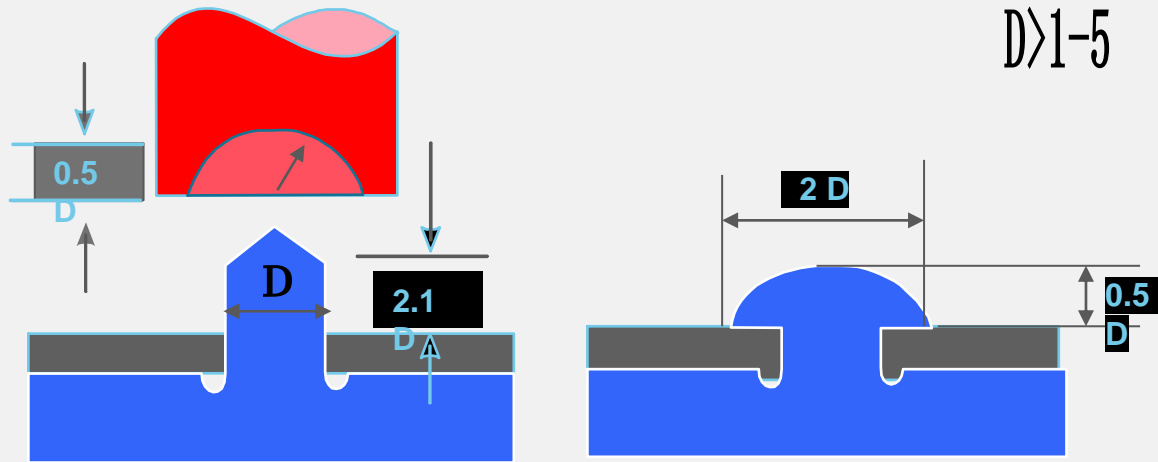

Before

After

**D = Stud diameter**

## Hollow Stake

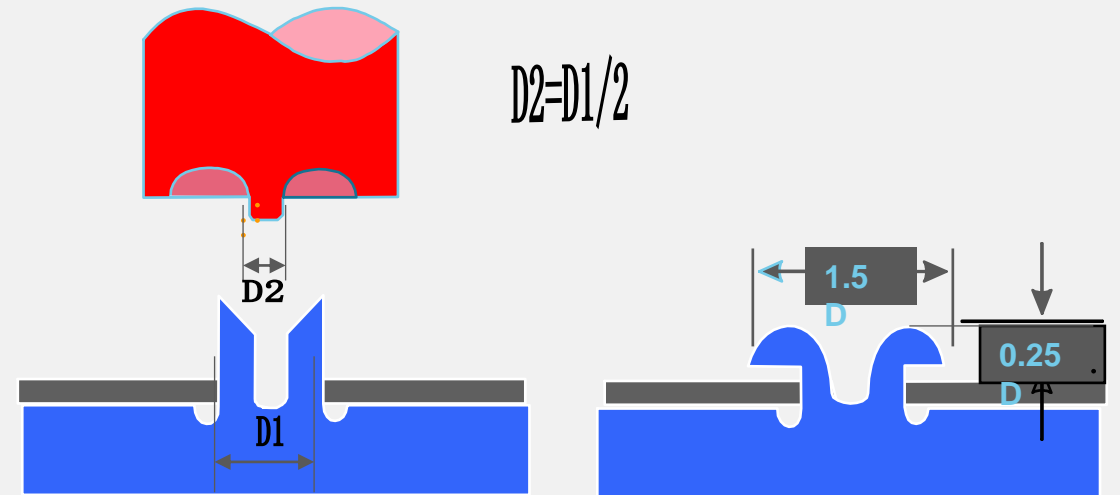

Before

After

**D = Stud diameter**



# Ultrasonic Stacking Design

None Cavity Tip Design

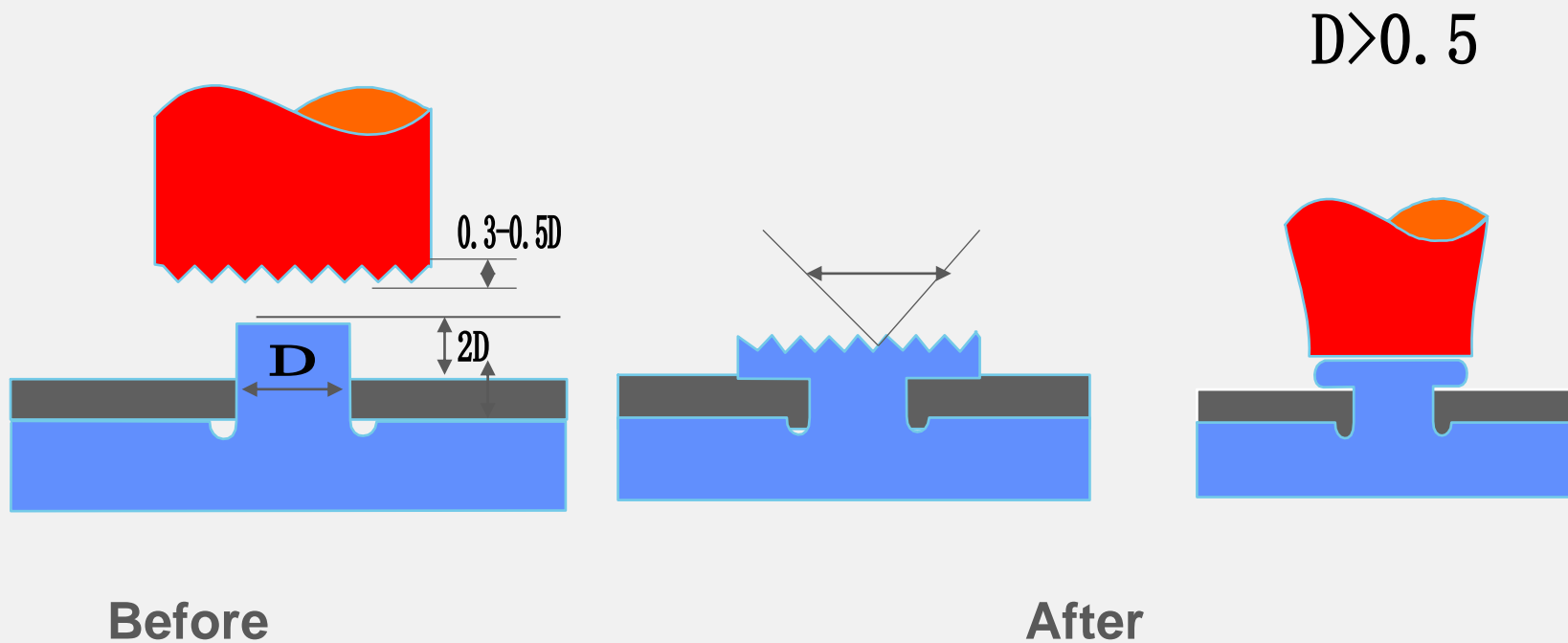

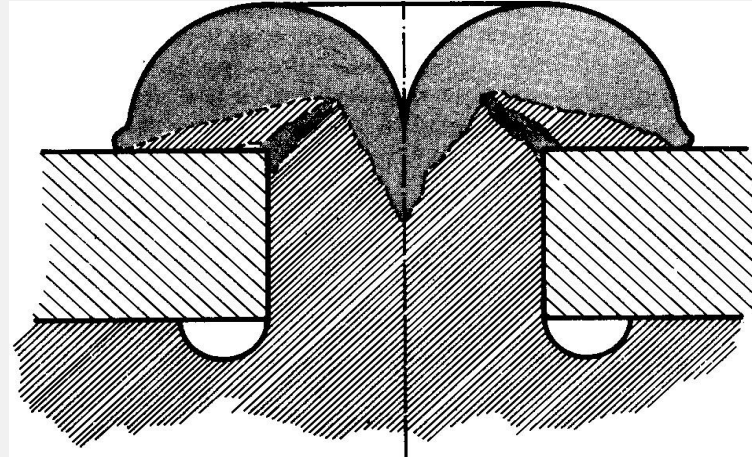
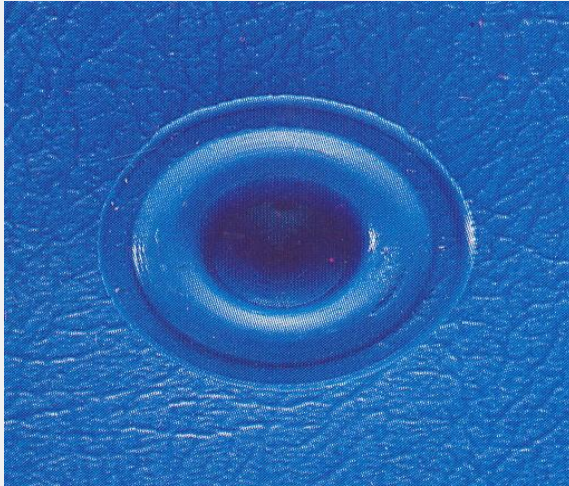



# Ultrasonic Plastic Spot Welding

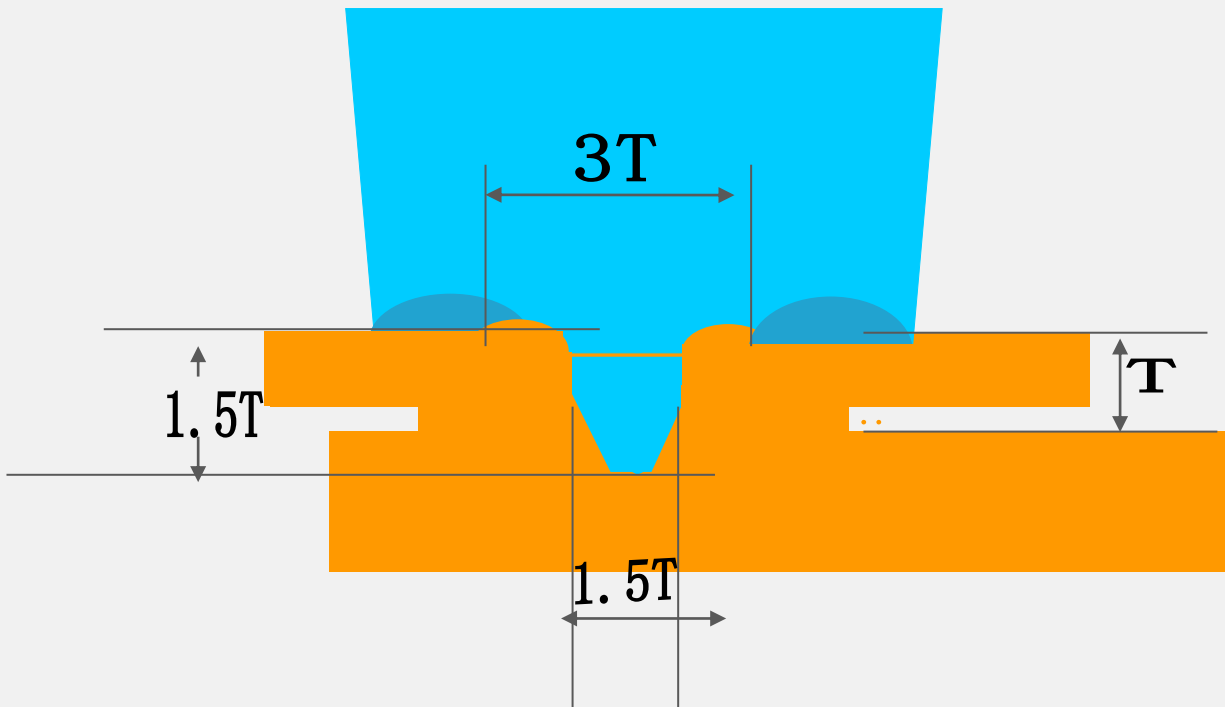

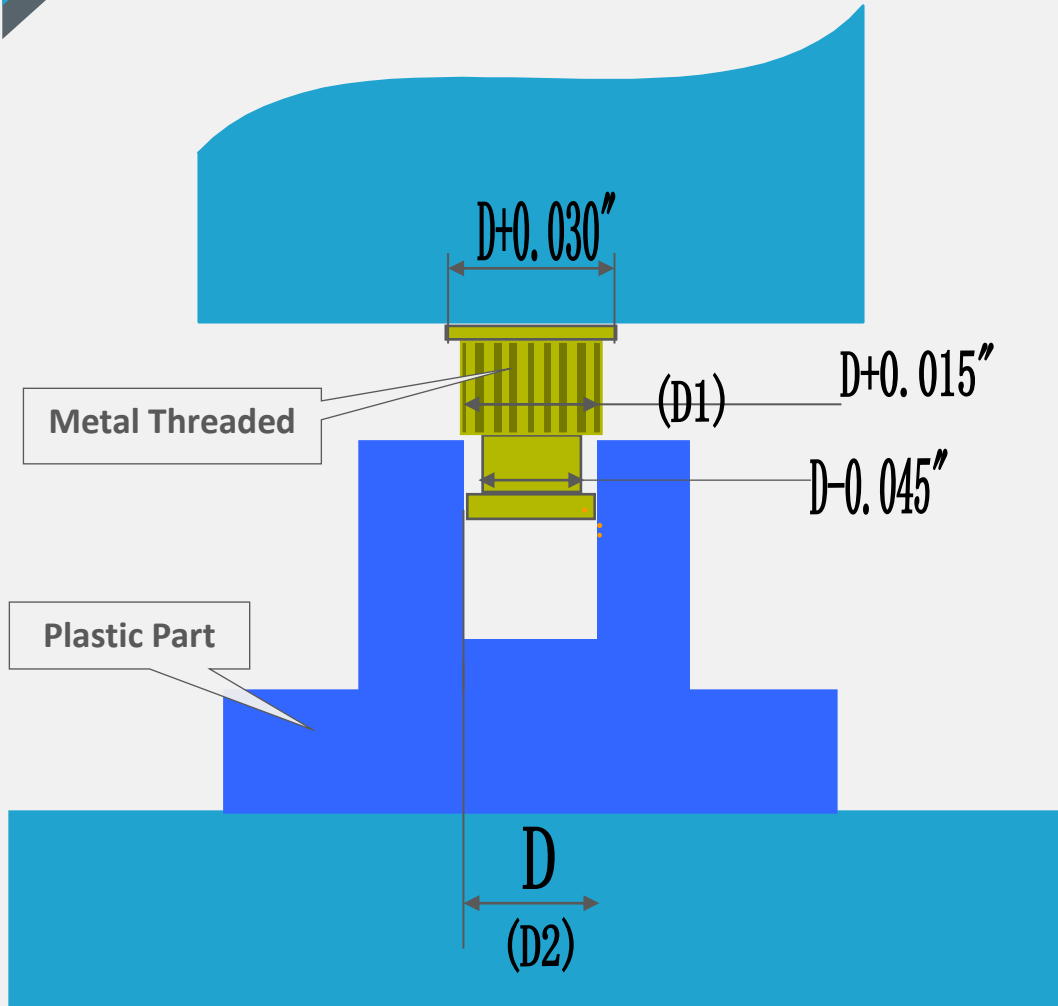

Metric threaded	bushing Length (mm)	Diameter (mm)		Insertion hole (mm) (rec.value)	Threaded bush
		D1	D2		
M3	5.8	3.9	4.7	4.0	
M4	8.2	5.5	6.3	5.6	
M5	9.5	6.3	7.1	6.4	
M6	12.7	7.9	8.7	8.0	
M8	12.7	9.5	10.2	9.6	

$D \leq 1/4'' - 1000W$

$D \leq 1/2'' - 2000W$





# Ultrasonic Insertion Samples

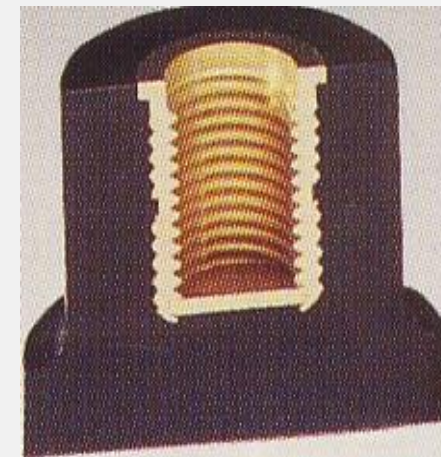
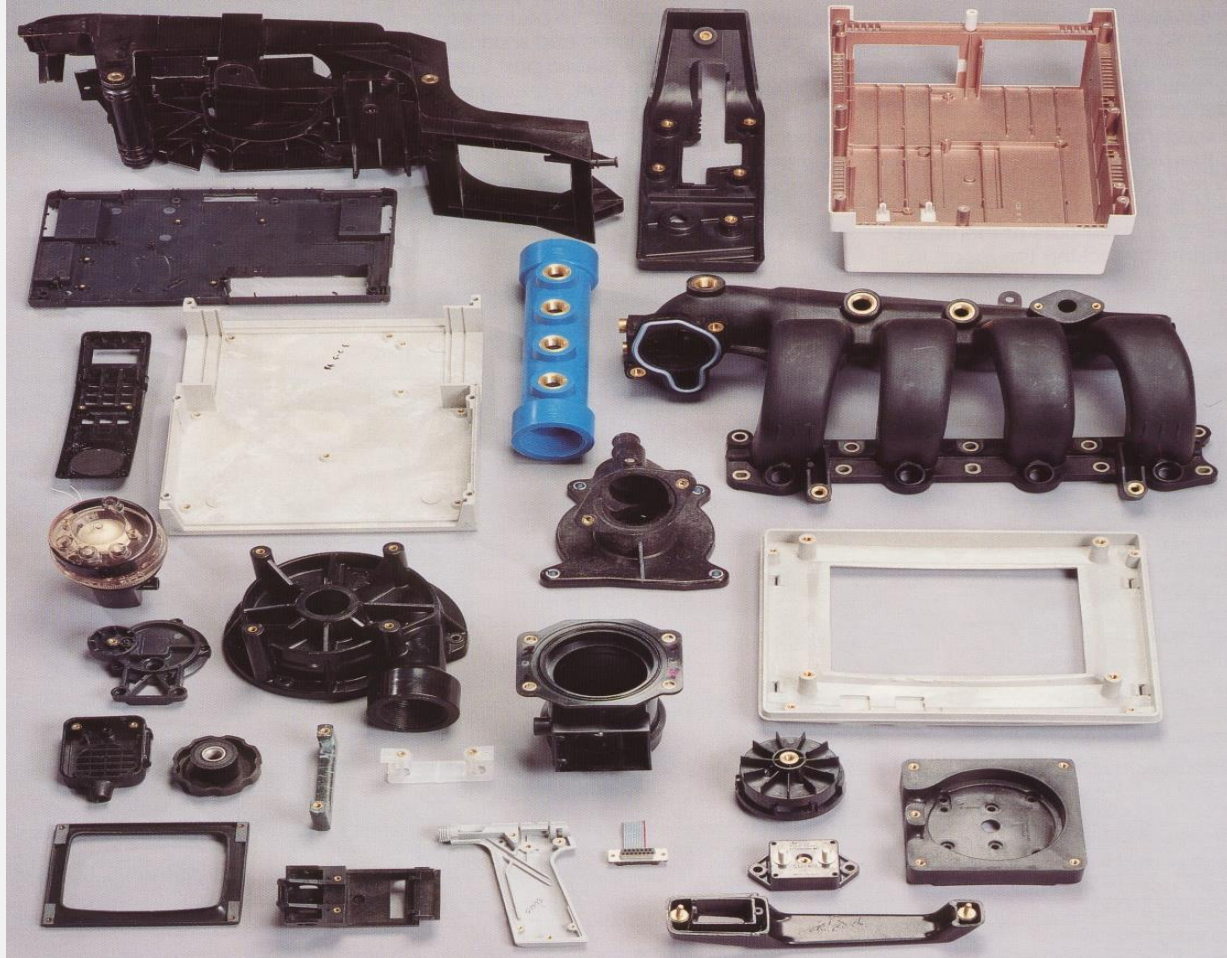



# Injection Gate Ultrasonic Cutting

## Good design

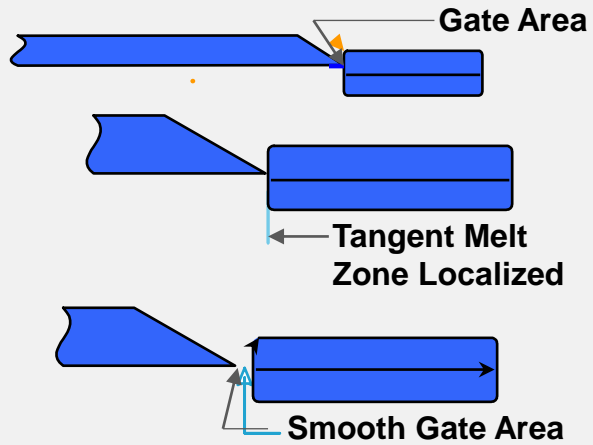

## Poor design

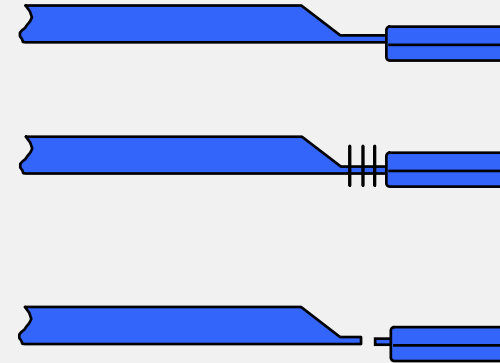

## Gate Size

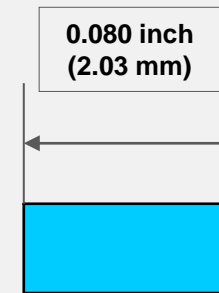
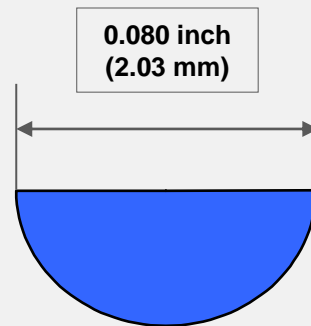
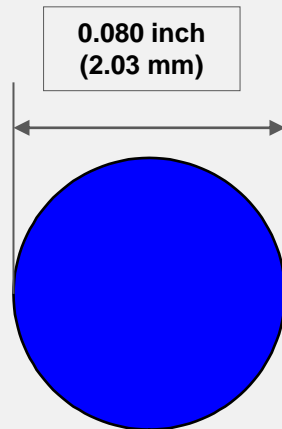

# Ultrasonic Plastic Welding

THERMOPLASTICS 热塑性塑胶	PRPOSED WELDING METHOD 焊接方法	Ultrasonic 超声波焊接					Hot-plate 热板			Vibration 震动	Spin 旋转	Radio Freq. 高频
		Near filed welding 近距离	Far filed welding 远距离	Inserting 埋接	Staking 铆接	Spot welding 点焊	On contact 接触* Low temp. 低温	On contact 接触** High temp. 高温	Non-contact 不接触***			
Acrylic/Styrene/Acrylonitrile(ASA)	丙烯酸 - 苯乙烯 - 丙烯	2-3	2 △	2	2	2	2-3	3	3	2	2	4
Acrylonireile/Butadiene/tyrene(ABS)	丙烯腈 - 丁二烯 - 苯乙烯 (超不碎胶)	1	1 △	1-2	1	1	1-2	2	3	2	1-2	4
Cellulose Acetate(CA)	纤维	2	2-3 △	2	2-3	2	3-4	3-4	3-4	2	2	3-4
Methacrylate(Acrylic)(PMMA)	甲基丙烯酸酯 (亚加力)	1-2	1-2 △	1-2	2	2	2	1	2-3	2-3	2	3-4
PA-Blends	尼龙混合物	3	3-4 △	3-4	3-4	3-4	2	3-4	3	2	2-3	4
PC-ABS-Blends	PC/ABS 混合物	2-3	3 △	3-4	3	2-3	2	3	3	2	2	4
PC-ABT-Blends	PC/ABT 混合物	2-3	3-4 △	3-4	3-4	2-3	2	3	3	2	2	4
Polyacetal(POM)	聚甲基 (赛钢)	2	2	2-3	2-3	2-3	1-2	2	2	2	2	4
polyamide(Nylon 6)	尼龙 6	2-3	2-3	2-3	2-3	2-3	3-4	3-4	2-3	1-2	1-2	3-4
polyamide(Nylon 6/6)	尼龙 6/6	2-2	2-3	2-3	3	3	2-3	2	2-3	1-2	2	3-4
polyamide-Copolymer(Nylon 6-3-T)	尼龙 6-3-T	2	2	2	2	2	2-3	3	3	2	2	3-4
Ploybutylene terephthalate(PBT)	聚丁烯酸脂	3molded parts 注塑件	2-3	2	2-3	2-3	3-4	3	3	2	2	4
		1foils 加薄胶膜										
Polycarbonate(PC)	聚碳酸酯 (防弹胶)	2	2 △	2	2	2	2-3	2-3	2	2	1-2	4
Ploybutylene(PE)	聚乙烯 (软胶)	3	4	3	3	2	1	2	3	3	2	4
Ploybutylene terephthalate(PET)	聚乙烯酸酯 (宝特胶)	3molded parts 注塑件	2-3	2-3	3	3	3-4	3	3	2	2-3	4
		1foils 加薄胶膜										4
Ploybutylene oxide(PPO)	聚氧化亚苯	2	2 △	2-3	2-3	2-3	2	2	3	2	2	4
Ploybutylene sulfide(PPS)	聚硫苯	2	2	2	2	2	2	3	3	2	2	4
Ploybutylene (PP)	聚丙烯 (百折胶)	3	4	3	3	2	1	2	3	2	2	4
Ploystyrene(PS)	聚苯乙烯 (硬胶)	1	1 △	1	1	1	1	2	3	2	1-2	4
Ploysulfone(PSO)	聚佩	2	2	2-3	2-3	2	2-3	2-3	3	2	2	4
Ployvinyl chloride(PVC)	聚氯乙烯	2-3with foils 加薄胶膜	3 △	2-3	2-3	2-3	1-2	3	3-4	2-3	2	1
PP-EPDM-Blends	PP/EPDM 混合物	3	3-4 △	2-3	2-3	2	2	2-3	2-3	2	2	4
PPO-Blends	聚氧化亚苯混合物	3 with foils 加薄胶膜	3-4 △	3-4	3-4	3	2	2-3	2-3	2	2	4
Styrene/Butadiene(SB)	苯乙烯 - 丁二烯	1	1 △	2	2	1	3	3	3	2	1-2	4

List of Symbols 符号代表: 1=very good 非常好 2=good 良好 3=limited 尚可 4=not possible 不可能

- ☪=Exhaust fan recommended 建议加排气扇
- △=Energy director recommended 建议焊接面加焊线
- ☪=Knurl faced horn recommended 建议焊头表面刻滚花纹
- ☪=Shear joint recommended 建议焊接面造剪切面

\* Hot plate temperature up to 290°C, Heat platens incontact with parts to be welded. 热板温度达到 290°C, 热板要与工件接触。

\*\* Hot plate temperature above 290°C, many applications with temperature ranges above 340°C. Heat platens incontact with parts to be welded. 热板温度在 290°C 以上, 热板要与工件接触, 很多次实例都要用约 340°C 范围温度。

\*\*\* Temperature ranges from 400°C to 650°C. NO contact between heat platens and parts to be welded. 热板温度在 400°C -650°C, 热板与工件不用接触。

# Thanks

---

Tel :+86-577-61517751

Fax :+86-577-61517750

Mob:+86 15918523336

Email :[alex.lee@mp-sonic.com](mailto:alex.lee@mp-sonic.com); [alexlee2696@163.com](mailto:alexlee2696@163.com)

Add :No.289, Weiqi Road, Yueqing Economic  
Development Zone, Wenzhou, China

Web:[www.cnzhenbo.com](http://www.cnzhenbo.com); [www.mp-sonic.cn](http://www.mp-sonic.cn)